

SMART AGRICULTURE MONITORING USING INTERNET OF THINGS TECHNOLOGY

*¹B.SAISINDHU, Assistant Professor, Dept of ECE,

*²B.SANTHOSH, Assistant Professor, Dept of ECE,

MOTHER THERESSA COLLEGE OF ENGINEERING & TECHNOLOGY, PEDDAPALLI.

ABSTRACT: Agriculture has been an indispensable element of every nation for an extended period. Plant cultivation can be approached from both a scientific and an artistic perspective. Modern farming has to change if it wants to keep up with the rapidly developing technology world. An essential part of smart farming is the Internet of Things. With the help of IoT sensors, crucial information on agricultural areas can be gathered. Connecting wireless sensor networks, gathering data from sensors in various locations, and communicating the data via a wireless protocol allows the monitoring of agricultural activity made possible by the Internet of Things (IoT). Using the NodeMCU platform, the intelligent agricultural gadget is controlled by the Internet of Things. A DC engine powers the gadget, which also has sensors for temperature, humidity, and wetness. This device measures the relative humidity and moisture content of the air. When the water level drops below a certain threshold, which is controlled by the system, self-watering begins. Variations in temperature are required for the display to work. The IoT gives weather reports that include the current date and time in addition to the temperature and precipitation totals. The individual commodities being cultivated determine whether temperature regulation is viable.

Keywords: IoT, Soil, Moisture and Temperature sensors, Relay, Wi-Fi module ESP8266, ThingSpeak

1. INTRODUCTION

India's income is largely derived from agriculture. The ability to cultivate land is crucial to human existence. There is no way to separate agricultural progress from human flourishing. Finally, the season and the availability of water affect the productivity of farms. In order to overcome challenges and produce successful agricultural outcomes, an IoT-based smart agriculture system is employed.

The main goal of agricultural monitoring systems on a global and regional scale is to provide reliable and current data on food production. The use of sensors to track

environmental factors including light, temperature, humidity, and soil moisture is central to internet-of-things (IoT) smart farming. Producers can keep an eye on their operations with the help of remote farm monitoring.

Smart farming, which makes use of the IoT, is superior to traditional farming methods. For the proposed irrigation system to be compatible with the Internet of Things (IoT), the ESP8266 NodeMCU Module and DHT11 Sensor are used. When the soil moisture level is low, the system will water the soil based on that reading and also notify the ThingSpeak Server of the situation. New sensors for agricultural irrigation systems, the Internet

of Things (IoT), and wireless sensor networks (WSN) can all work together to make autonomous irrigation systems a reality.

The system will decide which factors to track in an irrigation system, such as the weather, soil conditions, fertilizer application, and water amount and quality. It will also give a brief summary of the most common wireless technologies and nodes used in IoT and WSN to build smart irrigation systems.

2. LITERATURE SURVEY

The automatic irrigation and monitoring of a field by equipment that is facilitated by the Internet of Things (IoT) is an example of how to monitor a farming region. A system is built using the devices, and its operation is determined by the server using the data it receives.

Computer programs carry out the process autonomously. Through a wireless connection, the acquired data is transmitted to a web server database. In areas where it rains frequently and is cool, people use mechanical irrigation more often. Remote monitoring and control of the system is possible through a web-based interface.

Smart agriculture tracking devices that require manual configuration checks are one of the earliest methods for this. Farmers use this method to independently measure everything by taking a look at all the relevant aspects.

Devices and technologies that monitor people, inform them of what's happening, and trigger alarms are the main focus of the system, which relies on wireless sensor networks. Many believe that better farming will be possible with the help of robots and the Internet of Things (IoT).

A comprehensive computer system with displays and tools for analyzing

agricultural industry data is assembled at the conclusion of the system using cloud computing devices. A novel approach to smart farming is presented, utilizing wireless communication between a smart irrigator system and a smart sensor system. This tactic is inexpensive to implement. Through this platform, the agricultural system may be accessed and controlled by anybody with a computer, laptop, or smartphone.

3. BLOCK DIAGRAM

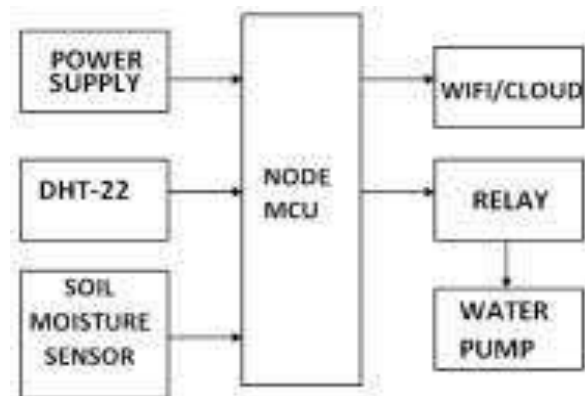

Figure 1: Block Diagram

Figure 1 is a block schematic of the suggested system that lays out all the necessary components.

Required Modules

- Hardware requirements
- Soil moisture sensor
- Temperature sensor (DHT-11)
- Relay
- Pump
- IoT (WI-FI module ESP8266)
- Power supply: 5V, 700mA Regulated power supply
- Software tools required
- Arduino IDE
- Things peak website

Soil Moisture sensor

Soil moisture sensor (Figure 2) available. They are monitoring the soil moisture level.

The output of the module is increased by the monitor if it is believed that the field is not receiving sufficient water. If it doesn't,

it's not up to par.

A user can set this device to water their plants at specific intervals based on the soil's moisture level. Crops, gardens, and farms get a lot of water from it.

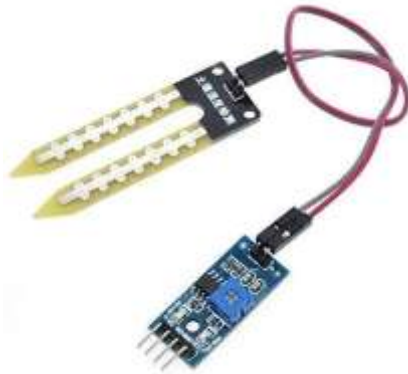

Figure 2: Soil Moisture Sensor
Temperature Sensor (DHT-11)

The DHT-11 Temperature Sensor has the ability to measure both the temperature and humidity of the air. A low-priced digital thermometer and hygrometer are shown in Figure 3. Its official name is the DHT-11. When we want to know how the air is, we use a thermometer and a capacitive humidity sensor. The electrical resistance of two devices is measured by the DHT-11 to determine the relative humidity. At that point, it digitizes the reading and transmits it to the data pin.

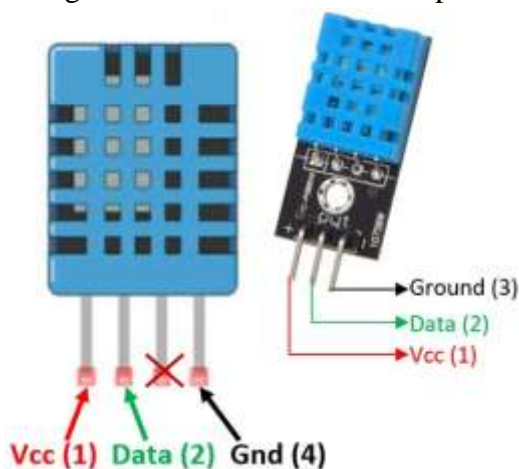

Figure 3: Temperature sensor

Relay

The function of a switch as an electrical valve is illustrated in Figure 4. A third set

of terminals can be touched, and another set of terminals can receive control signals. The switch may have several contacts of varying sizes and shapes. Any kind of physical touch has the power to solidify or rupture a marriage. Thanks to the relay, we can run the water pump and ensure that the crop is consistently moist.



Figure 4: Relay

Water pump

A tiny, inexpensive pump motor for use underwater is shown in Figure 5. The small micro submersible water pump from DC 3-6V works as advertised. It is capable of operating on a voltage range of 2.5 to 6 volts. It operates on 220 mA and has a water-moving capacity of 120 liters per hour. Just plug it into water, attach the tube conduit to the motor's outlet, and you're good to go.



Figure 5: Water Pump

IoT (WI-FI module ESP8266)

The NodeMCU (ESP8266) is a microcontroller that comes equipped with a Wi-Fi module, as seen in Figure 6. Thirteen of the seventeen pins on this device are designated as GPIO (General

Purpose Input/Output). They can receive data that can be transmitted to other devices, and you can connect many monitors to them. The NodeMCU comes with 128 KB of RAM and 4 MB of SW for storing data and programs. Code received over USB is saved by the NodeMCU. The data from the sensors is stored and checked by the NodeMCU in this endless loop. Based on the information it receives, this module activates the relay module. You can activate or deactivate the pump using the relay module. With a frequency range of 80MHz to 160MHz and a voltage range of 3V to 3.6V, the NodeMCU can function. Indoors, the NodeMCU's Wi-Fi module can cover up to 92 meters, or 46 meters.

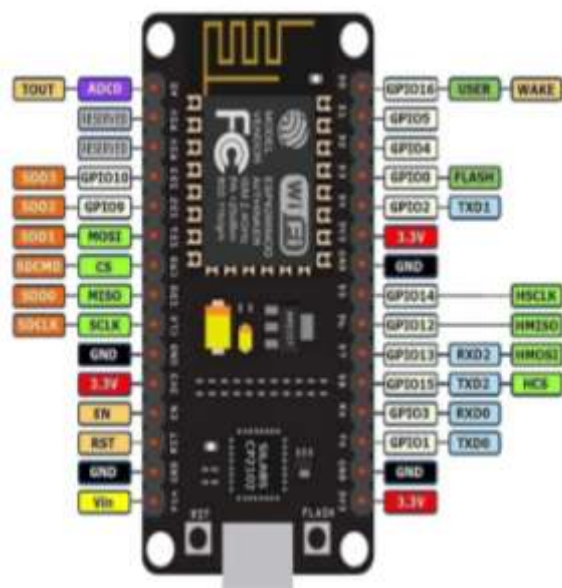

Figure 6: ESP8266 module

Power Supply

According to Figure 7, the responsibility of delivering electricity to a load lies with the power source. To achieve the desired voltage, current, and frequency, a power supply can convert the flow of power from one source to another. to alleviate the load. One term for a source of electricity is an electrical power converter. Although certain materials are tool-specific, others can stand on their own.



Figure 7: Block diagram of a fixed regulated power supply

Arduino IDE

The Arduino IDE is compatible with a wide variety of hardware. For its operations, it relies on C and C++. Using third-party cores and other development boards from different businesses, you can create apps for boards that are compatible with Arduino.

Thingspeak website

The ThingsSpeak platform enables the storage and communication of IoT-related data. Examine a live feed of data while gazing at the eerie sky. Everythingspeak maintains constant communication with the gadgets. It immediately creates a copy of the source material and informs the user of it. The internal workings of ThingSpeak are illustrated in Figure 8.

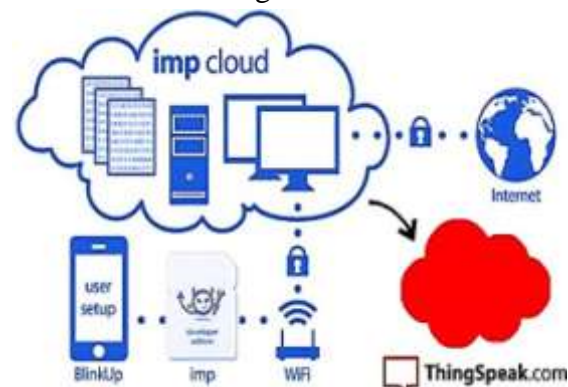

Figure 8: Internal Work of ThingSpeak

4. WORKING

The efficacy of the technology employed for smart farm monitoring is tested in several contexts. No matter the weather, the soil moisture sensor will reliably determine how much moisture is present in the soil. The quantity of moisture produced is adjusted according to the weather. People can communicate wirelessly with fidelity plugs.

Soil resistivity is the primary metric used

by the soil moisture monitor. A zero reading on the rain gauge indicates that precipitation is imminent. As soon as the NodeMCU receives the number from the microcontroller, the motor pump is disabled. To determine the soil's dryness, the maximum value that can be used is 1023. The computer activates the relay and starts the motor whenever the sensor registers a value greater than the threshold that has been previously set. Based on the amount of water that the plants absorb, you have the option to program the motor pump to automatically switch it on and off.

ADVANTAGES

- The purchasing price is fair, and maintenance is simple.
- The products that were utilized are readily available.
- The ability to view things using a mobile device or
- A portable device with an internet connection. Every contemporary amenity is available here.
- In the absence of the cultivator.
- The data is current, so farmers can trust it.
- Considering the present condition of the harvest.
- Improve the accuracy of the crop details.
- Incorporate additional sensors into the existing arrangement.

5. RESULTS AND ANALYSIS

Farming is one of the most significant industries that should use modern technology. The project's core objective is that. The Internet of Things (IoT) makes it simple to monitor agricultural operations. Modern farmers place a premium on the aforementioned advantages, especially the reduction of water and labor requirements. Smart irrigation systems can be implemented in farms through the use of

sensor networks. Cloud storage stores the Internet of Things data for the client. This facilitates the rapid detection of crop changes by researchers. The custom hardware bundle for the proposed model is shown in Figure 9.

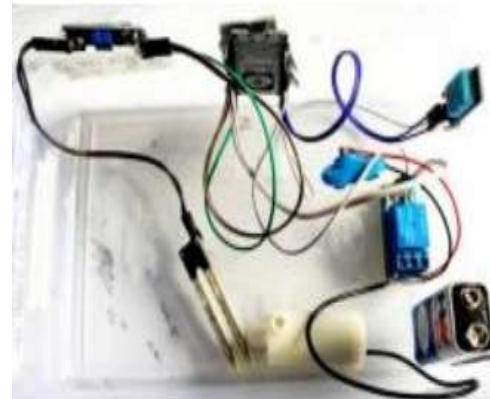

Figure 9: Iot Based Smart Agriculture Monitoring System

Figures 10, 11, and 12 display the measurements and earth facts that were discovered. Moisture, relative humidity, and temperature are a few of them.



Figure 10: Temperature Measurement

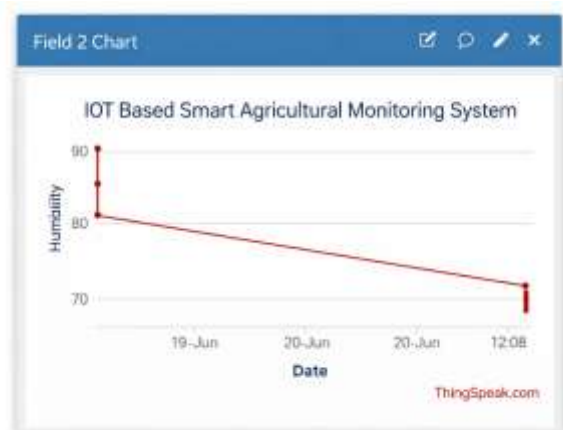

Figure 11: Humidity Measurement



Figure 12: Soil Moisture Measurement

7. CONCLUSION

The Internet of Things will help farmers do better work. In order to administer and monitor irrigation systems effectively, the IoT is utilized to forecast soil moisture and humidity levels. The Internet of Things (IoT) offers several potential benefits to farmers, including the ability to monitor crop health, increase soil quality, decrease pesticide and insecticide use, and optimize water and time management. This approach promotes smart farming, streamlines agricultural operations, and decreases the amount of labor required of farmers. Smart farming has many advantages, one of which is the possibility of reaching more clients with a single engagement and less effort.

REFERENCES

1. Rajalakshmi.P and S. Devi Mahalakshmi, "IOT BasedCrop Field Monitoring and Irrigation Automation", 10thInternational conference on Intelligent systems andcontrol (ISCO), 2016.
2. Joaquin Gutierrez, Juan Francisco Villa-Medina et.al,"Automated Irrigation System Using a Wireless SensorNetwork and GPRS Module", IEEE Transactions onInstrumentation and Measurement, 2013.
3. Dr. V. Vidya Devi and G. Meena Kumari, "Real TimeAutomation and Monitoring System for Modernized Agriculture", International Journal of Review andResearch in Applied Sciences and Engineering, Vol3no.1. pp 7-12, 2013.
4. Basha, Elizabeth, and Daniela Rus, "Design of earlywarning flood detection systems for developing countries", International Conference on Information andCommunication Technologies and Development, 2007.
5. K. Jyostna Vanaja, Aala Suresh et.al, "IOT basedAgriculture System Using NodeMCU", International Research Journal of Engineering and Technology,Vol.05.
6. T. Rajesh, Y. Thrinayana and D. Srinivasulu "IoT basedsmart agriculture monitoring system", InternationalResearch Journal of Engineering and Technology,Vol.07.